

# RILEY

S C O O T E R S

**RS3 - The all new commuter scooter**



# Folding Stages





# USPs

## Compact

RS3 folds to a cubic volume of 0.084m<sup>3</sup>, which is less than a Brompton Bike at 0.089m<sup>3</sup>.

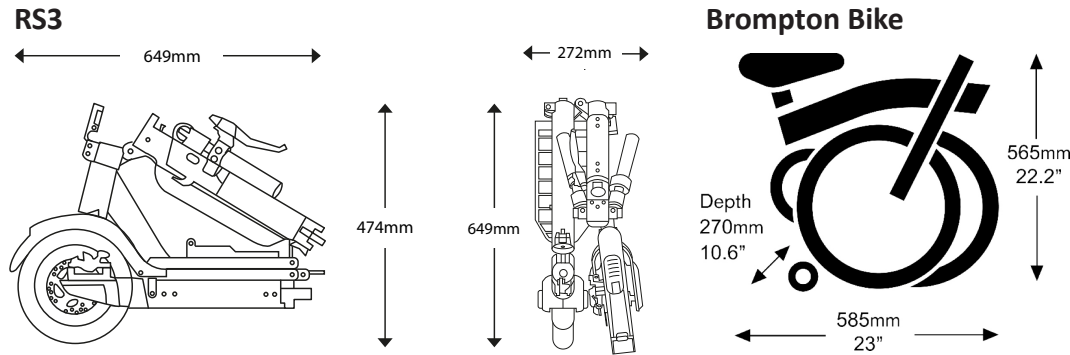

## User Friendly

RS3 has a companion app which you can use to lock the scooter, track rides and more. It also comes with front and rear LED lights as well as an LED display showing speed, battery range and driving mode.

RS3 has a powerful 350W motor combined with a long range detachable battery with a maximum range of 25km. It is also equipped with E-ABS and a disk brake dual braking system. The frame is made from strong Aircraft grade aluminium.

## Portable

Once folded, RS3 can easily be carried on public transport and is the ideal product for first mile/last mile commuting.

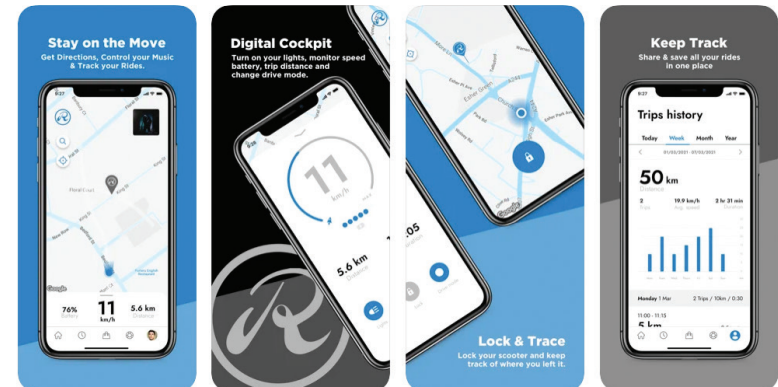
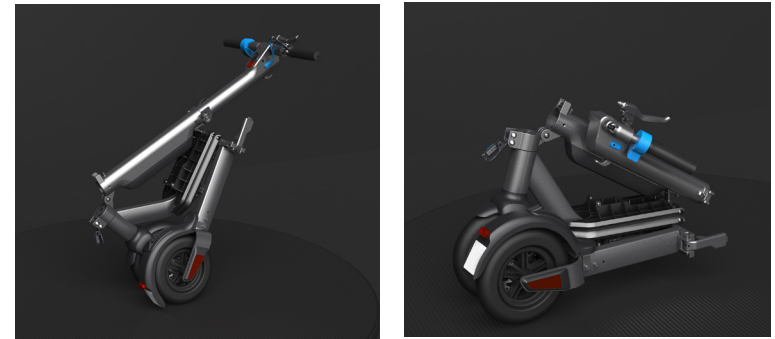



# Scooter Specifications

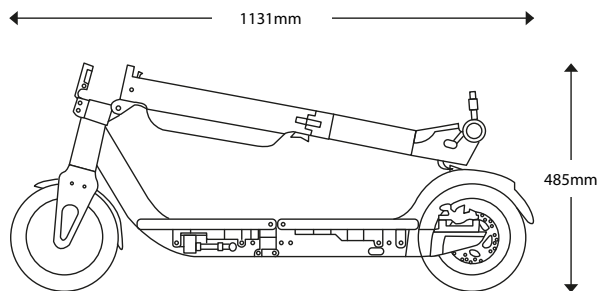
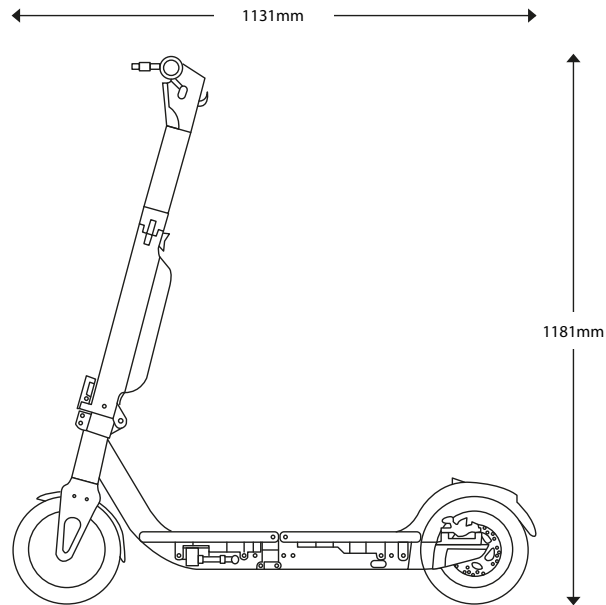

Unfolded size	1131x170x1181mm
Folded size	649x272x474mm
Max range	15.5 miles (25km)
Max speed	15.5 mph (25km/h)
Tyre size	8.5 inch pneumatic air tyre - with inner tube
Tyre pressure	35 P.S.I (2.41 Bar)
Net weight	14kg
Frame material	Aviation aluminum alloy
Motor power	350W - 36V motor - 700W peak capacity
Head light	LED
Tail light	LED
Charger parameters	DC42V/2A
Climbing angle	15°
Waterproof level	IP54
Charging time	Approx. 2 hours
Maximum load	120kg
Hook load	10kg
Battery	6.4aH Battery
Battery safety	Anti-fire battery case
Driving modes	3 (beginner, eco, sport)



## The Future Of City Commuting

Riley Scooters are designed with convenience and practicality in mind, as well as providing an environmentally friendly solution to commuting needs.

Our RS3 scooter is positioned at the mid to high end of the market, due to its innovative design and high quality craftsmanship.

Our RS3 scooter is not just an electric scooter, it is a compact, foldable scooter allowing commuters to take on buses, trains and in cars or taxis, making it easy to do full commutes or provide transport for the first and last mile.

At just 14kg, the foldable scooter can be carried in a backpack allowing for easy transportation. Taking up less than one cubic metre, it can be stored in small spaces. On top of that, just click out the battery and charge it easily at home or in the workplace so you always have enough charge!

Get going with a Riley Scooter.



**We have designed a compact e-scooter that folds up in a revolutionary way which is fit for commuters to take on public transport, as well as ideal for consumers with limited storage space.**



# The Challenge



## Difficult to transport

Currently E-scooters can fold in half, but are still difficult to carry and transport due to their size and weight. They do not fit within TFL approved dimensions to be transported on any form of public transport during “rush hour”.



## Long charging times

E-scooters are limited by the range of the battery and take a considerable number of hours to charge. Scooters without detachable batteries can make charging inconvenient and sometimes impractical.



## Difficult to store

Most E-scooters on the market are very awkward to store due to their size, and often not suitable for inner city living.



## New E-scooter legislation

Changes in government legislation has legalised the use of E-scooters on the road for the first time in the UK (through hire companies only). They are becoming legal all over Europe including France and Germany.



## Post Covid-19 commuting

Since the outbreak of Covid-19, the world has been looking at what the new world will look like, particularly when public transport is crowded. E-scooters will allow for socially distanced commuting and transportation.



## Environment friendly options

The modern day consumer is aware of their carbon footprint and is looking for environmentally friendly, yet convenient modes of transport.



# The Solution - RS3



## Foldable, easy to carry

RS3 is easily foldable and can be placed inside a backpack for easy transportation. Furthermore, at 14kg the scooter is very light, making it easy to carry and move around.



## Clip-in battery

Riley Scooters have a detachable battery allowing you to switch the battery for a fully charged spare one, eliminating the need to wait for the battery to recharge.



## Easy to store

RS3 folds up easily into a very compact size, making it easy to fit within confined spaces such as a cupboard, a car boot or under a desk.



## Road safe

Riley Scooters have disc brakes, integrated headlight, brake light, cruise control and a speedometer to allow safe road travel.

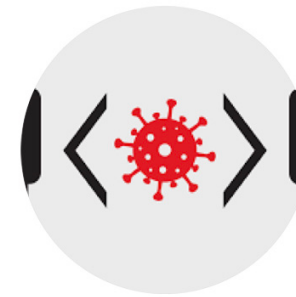

## Social distancing safe

Riley Scooters allow commuters to either avoid public transport altogether or switch out parts of their journey, even during rush hour, for an outdoor, safe, alternative.



## Environmentally friendly

Riley Scooters are electric and therefore contribute significantly less to carbon emissions compared to fuel powered vehicles.

# Market Positioning Strategy

**RS3 will be positioned at the mid to high end of the market. As the E-scooter is made using the best mechanisms and materials we will charge a premium price. The RS3 will be:**

- Higher quality than brands such as Xiaomi, Segway, Reid and Egret.
- Cheaper than brands such as Inokim and 8TEV.
- More practical than any E-scooter on the market, due to being able to fold up into a compact size, allowing for ease of transportation and storage (TFL compliant on public transport).

**Riley Scooters will challenge existing competition by:**

- Creating a brand new, innovative product that gives commuters and city dwellers a foldable, compact E-scooter, with a premium ride quality.
- Competing in other markets such as foldable bikes e.g. Brompton Bikes. As our product can be used for the same purpose, and is slightly cheaper, consumers may be more inclined to use our product as they won't work up a sweat before work.

## Top three competitors

(see market positioning graph):

### Xiaomi Pro 2

Price: 3

Quality 4



### Pure Air Pro

Price: 4

Quality: 4



### Segway Max G30

Price: 4

Quality: 3







# Market Positioning Graph

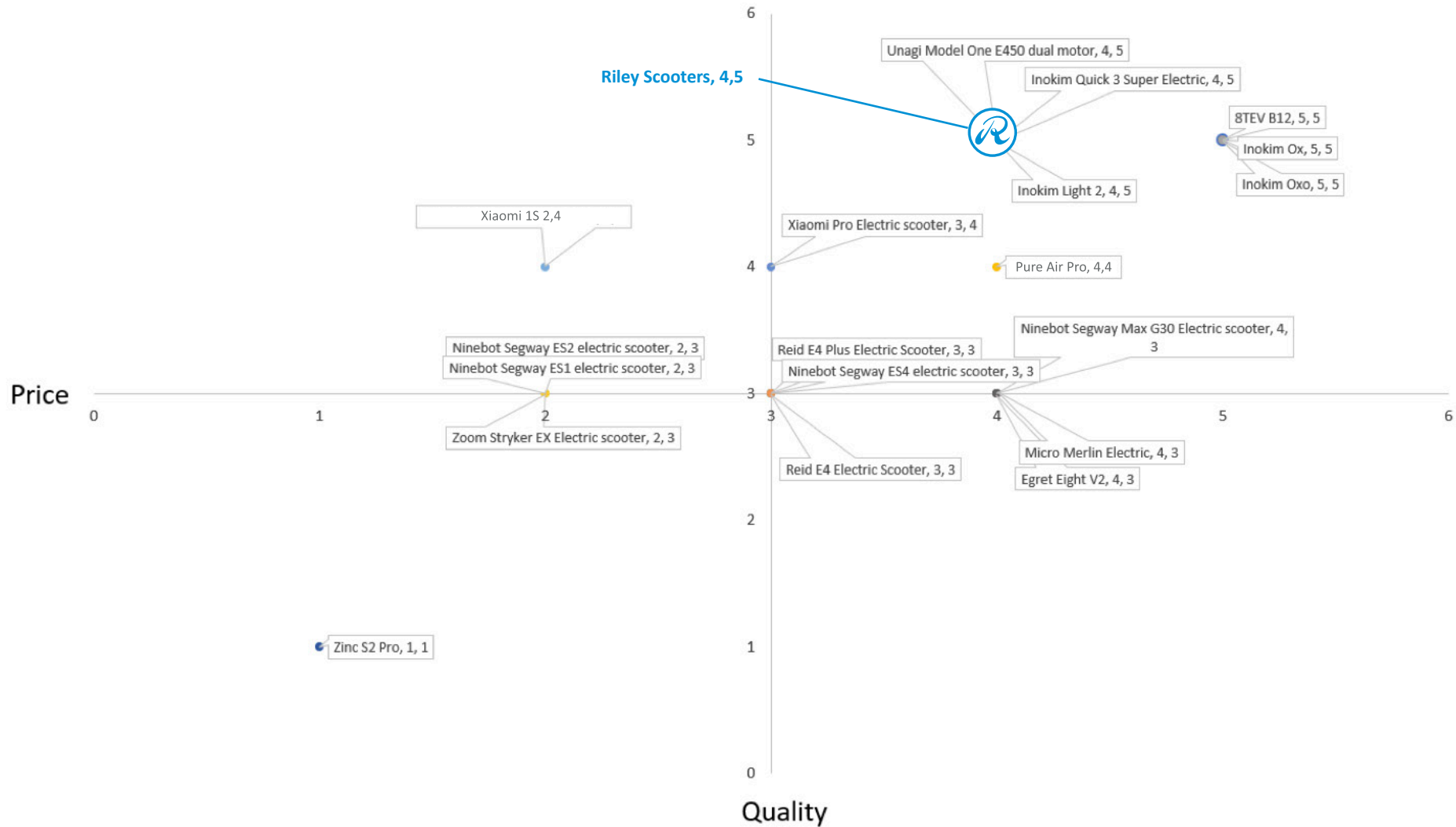

# **RILEY**

SCOOTERS

  
riley scooters

  
riley.scooters

  
riley\_scooters