

MAXVIEW



MXL017/50/65/85 Target (all models) **Installation & operating instructions**

UK contact:

Helpline: +44 (0)1553 811000
Email: support@maxview.co.uk
Web: www.maxview.co.uk

Contents:

Introduction	2	Connection diagram	11
Proper use & operation	2	Attaching Satellite Dish to Unit	11
Safety precautions	3	Finding a satellite	12
Application example	4	Reference	12
Connections & features	5	Interface details	13
Product contents	5	How to operate your system	13
Required tools and equipment	5	Ignition mode	14
Selecting an installation location	6	Connecting to a Satellite Receiver	14
Positioning Control Box	6	Power consumption	14
Attaching Antenna Mount Plate and LNB Park Plate	7	Software update	15
Electrical installation	8	Fault finding	16
Attaching Antenna Unit to Mount Plate	9	Error modes	16-17
Installing cables	9	Skew adjustment	18
Installing Cable Entry Plate	10	Guarantee	19
Installing Control Box	10	Environmental Specifications	19 20

Introduction:

Please read these instructions fully before using the antenna for the first time. The operation of the antenna has been designed to be as simple as possible however should you require any technical assistance please contact Maxview customer service on +44 (0)1553 811000 or visit www.maxview.co.uk.

Proper use & operation:

The Target is designed to be installed in a motorhome, caravan or horsebox to automatically locate a television broadcast satellite when the vehicle is stationary. The system comprises of 2 main components.

1. The Antenna which is to be permanently mounted externally to the roof structure of a motorhome/caravan horsebox. The construction of the roof structure should be suitably robust and have no protruding obstacles
2. The Control Box is designed to be mounted internally in a cupboard. This controls the antenna unit through a cable connection and is powered by 12v DC only.

Use of the equipment for any other purpose than the one specified is not permitted and will invalidate the warranty.

All instructions and models are subject to change. In accordance with policy of progressive product, the company reserve the right to alter specifications.

Copyright© these instructions are the sole property of Maxview Ltd and may not be reproduced. Please keep these instructions safe for future reference.

Recycle packaging where facilities exist.

Safety precautions:

Read this manual carefully and become familiar with your satellite antenna. Understand its applications, its limitations and any hazards involved. Failure to follow all instructions listed below may result in electric shock, fire and/or serious injury. Maxview declines all responsibility in the event of incident or accident if they are due to a non observation of the installation instructions or the way the product is used.

No modifications are permissible to the Antenna Unit & Control Box.

Installation

- Installation should be carried out by a competent person
- Take care when working at heights keeping work area clean and tidy to avoid trip hazards
- Use creeper boards where necessary to ensure roof construction can support your weight
- Use a recommended adhesive from page 10 to bond the antenna unit to vehicle roof and follow the manufacturer's instructions during application
- Do not travel until adhesive has cured noting that curing times vary with weather conditions
- Power tools should be used in accordance with manufacturer's instructions
- All electrical work should be carried out by a competent person. If in doubt seek advice from a qualified electrician
- The Control Box is for internal use only and is not waterproof

Operation

- Before starting your journey check that antenna is in the park position
- The maximum speed of vehicle with antenna mounted on roof is 81mph (130km/h)
- Never operate the antenna if someone is in close proximity of the antenna
- Disconnect power to the antenna before installation or adjusting LNB skew angle
- If high winds or electrical storms are anticipated lower antenna to park position
- Maintain adequate ventilation around the Control Box to avoid overheating
- Do not allow children to operate the antenna unit
- Remove Control Box fuse before accessing the roof space around the antenna unit
- Do not operate the Target with snow or ice on the antenna

Servicing

- If in the event that you do experience a problem with the system call Maxview Customer Service +44 (0)1553 811000 with your model & serial number to hand
- Any inspection or repair must be carried out by Maxview or an appointed representative of the manufacturer
- No regular maintenance required on the system
- Do not remove cover on Antenna or Control Box
- Do not use solvent or abrasive cleaning agents on the system
- Use a soft damp cloth to clean the Control Box
- Use a suitable mild detergent to clean the Antenna Unit
- Do not pressure wash the Antenna Unit
- Check the Antenna Unit fixings for mechanical integrity at least once a year

Application example:



A. Antenna

The Antenna is mounted to the roof. It uses electric motors to scan for satellite signals.

The single variant has 2 cable connections; 1 for controlling the motors and 1 satellite signal cable from the single LNB.

The twin variant has 3 cable connections; 1 for controlling the motors and 2 satellite signal cables from the twin LNB.

The quad variant has 5 cable connections; 1 for controlling the motors and 4 satellite signal cables from the single LNB.

B. Control Box

The Control Box requires wired connections for power, antenna control and satellite signal. It can be mounted discretely in a cupboard and can be fixed vertically and horizontally.

Connections and features:

Control Box:

- | | | | |
|-----------------|--------------------|-----------------------|-------------------------|
| 1. Fuse 4A | 4. Sync Button | 7. Receiver | 10. Installation Button |
| 2. Power Switch | 5. Status LNB | 8. LNB in | 11. Power Input |
| 3. Power LED | 6. USB update port | 9. Antenna Connectors | |

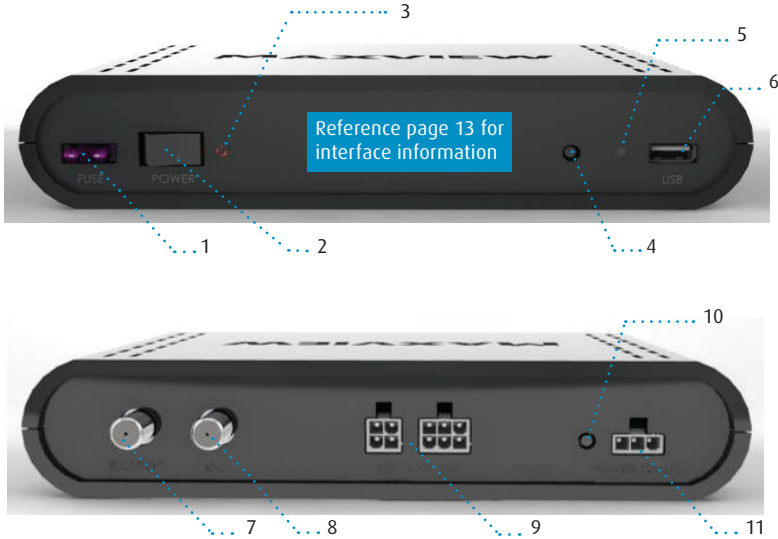

Product contents:

- > Antenna Unit / Control Box
- > 65/85cm Antenna (separate carton) 50cm Antenna (Fitted)
- > Accessory Pack
 - > LNB Park Plate x 1
 - > Control Box bracket x 2
 - > No.10 Screws x 6
 - > No.6 Screws x 4
 - > Cable Clips x 6
 - x 12 for quad
 - > M6 Button Head Screw x 4 (not included in 50cm model)
 - > M6 Locking Nut x 4 (not included in 50cm model)
 - > 6mm Plastic Washer x 4 (not included in 50cm model)
 - > Cable Entry Plate x 1

Required tools and equipment (not supplied):

- > 32mm hole saw
- > 2.5mm twist drill
- > Power Drill
- > No.2 Phillips screwdriver
- > Weather Resistant Elastic Adhesive* and Applicator gun
- > Surface Cleaner
- > 10mm spanner
- > Hexagonal socket key 4mm
- > Deburrer/Round File/Emery paper
- > Conduit (recommend method for securing cables)
- > Automotive 2.5mm² cable
- > Electrical connector block
- > Flylead (for connection to satellite receiver)

*Maxview recommends the following adhesives:

- > Sikaflex®-512 Caravan
- > Geocel® Geobond HM
- > Sikaflex®-252

Selecting an installation location:

Positioning the Antenna Unit

- > Check for obstructions such as roof lights and vents.
- > Check for electrical cables beneath screw fixing points.
- > Check Antenna Unit cables will reach Control Box (Maxview can supply extended cables).
- > Do not allow the dish to overhang the edge of the vehicle
- > Clearance around antenna system when in use is shown with reference I

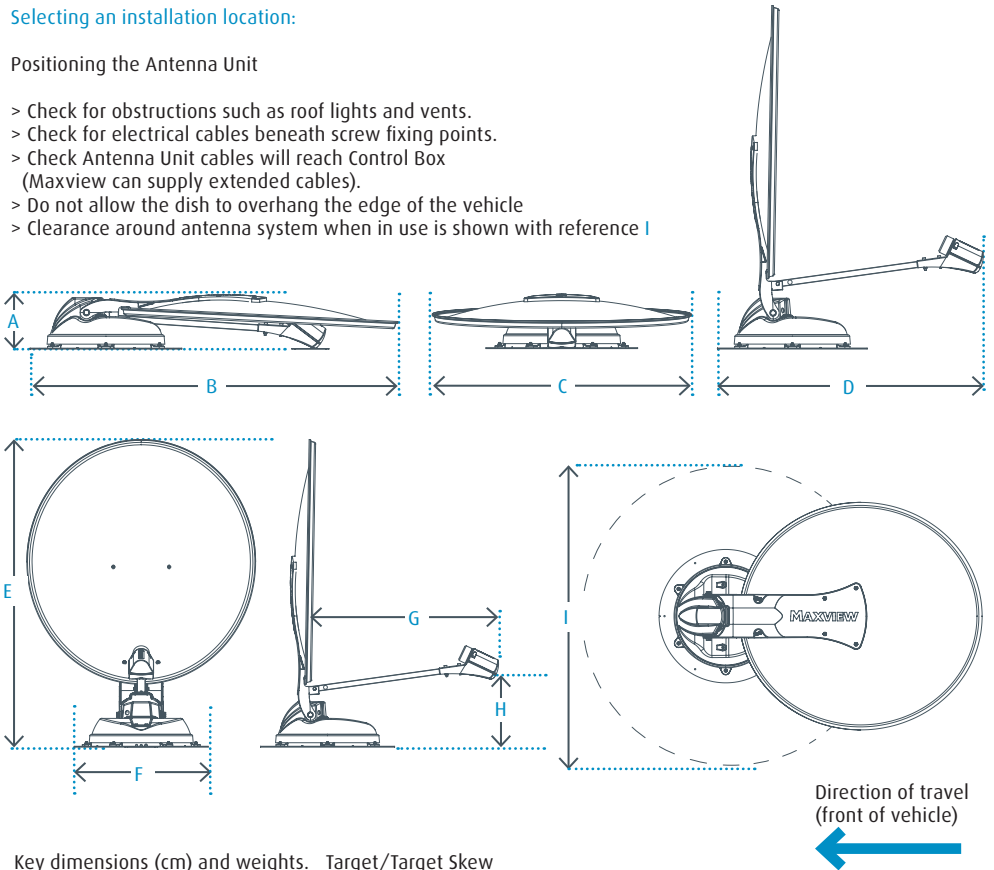

Key dimensions (cm) and weights. Target/Target Skew

50cm: System weight 9kg			65cm: System weight 10kg			85cm: System weight 11kg		
A: 17	D: 60	G: 45	A: 17	D: 65/66	G: 52/53	A: 17	D: 87/88	G: 64/65
B: 80	E: 79	H: 14	B: 100	E: 96	H: 15	B: 117	E: 113	H: 14
C: 50	F: $\varnothing 43^*$	I: 102	C: 67	F: $\varnothing 43^*$	I: 110	C: 85	F: $\varnothing 43^*$	I: 125

*Mounting plate

Positioning Control Box:

Site the Control Box in a convenient location where:

- > User can control the unit with the control box
- > Front and rear connections are accessible
- > Cables can be routed and concealed neatly
- > There is an electrical supply of 12V dc permanent and ignition
- > There is adequate ventilation
- > The Control Box is not encased with metal
- > Material construction and thickness is suitable for fixings

Attaching Antenna Mount Plate & LNB Park Plate:

1. Remove Antenna Unit from wooden transit packaging
2. Remove mounting plate from Antenna Unit by removing 6 x M6 nuts using 10mm spanner
3. Clean roof, Mounting Plate and LNB Park Plate in accordance with adhesive manufacturer's guidelines
4. Mark a centre line for the antenna making sure dish will not overhang vehicle
5. Align notches on plate with centre line
6. Mark the position of 6 screw fixing holes
7. Mark position of LNB Park Plate
8. Drill 6 x 2.5mm pilot holes into the roof

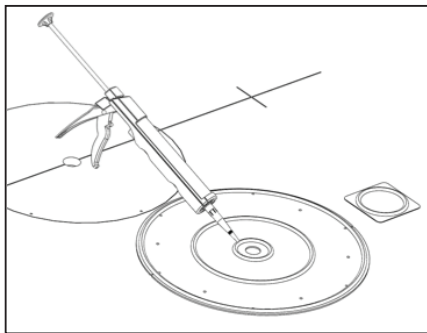
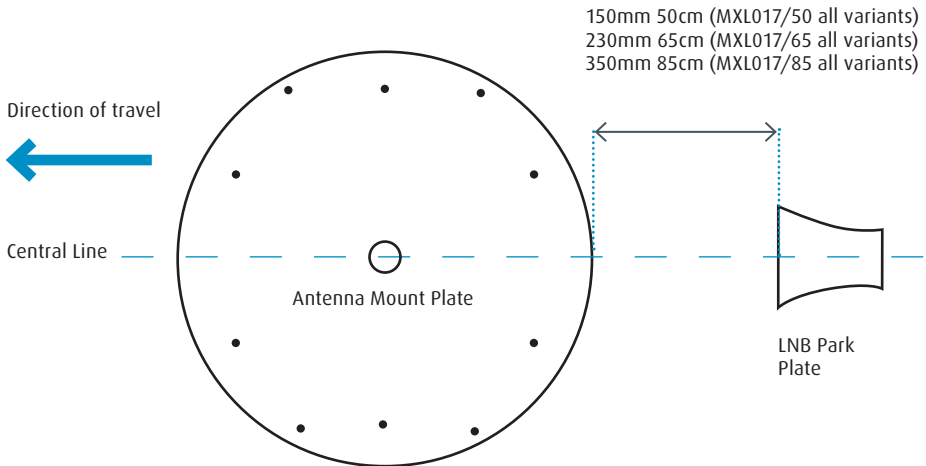

9. Apply adhesive to entire surface of Antenna Mounting Plate and LNB Park Plate and firmly place them into position

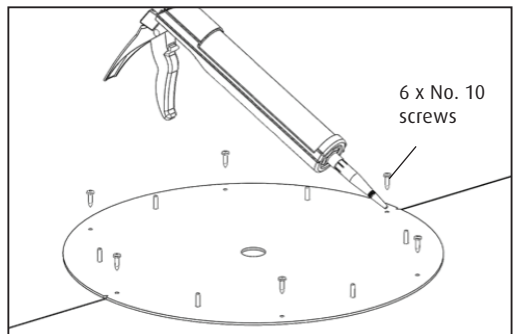

10. Place a small amount of adhesive into each hole before screwing plate to roof
11. Wipe off excess adhesive with a cloth

Note:

- Follow manufacturer's instructions when applying adhesive. Do not travel until adhesive has cured noting that curing times vary with weather conditions
- Take care when working at heights. Always follow ladder manufacturer's safety advice
- Use creeper boards where necessary to ensure roof construction can support your weight
- Power tools should be used in accordance with manufacturer's instructions

Electrical installation:

Whilst the adhesive is curing prepare the electrical connections for the Control Box. The Control Box requires a permanent 12V supply and a secondary 12V supply that provides power when the engine of the vehicle is running. Note: the brake light circuit is not suitable.

It is recommended to create a new circuit direct to the battery using a minimum cable cross sectional area of 2.5mm² and an inline fuse of 5A. Do not connect to existing circuits that supply high power devices such as water pumps, air conditioning units or sources of interference such as electric igniters for gas stoves. Route cables carefully avoiding areas of excessive heat such exhaust systems and any moving parts in the engine compartment or drive shafts.

Power Cable colours:
 Black Negative Earth
 Green Ignition (+12V)
 Red +12V

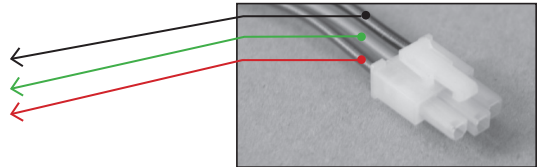

Join Power Cable to new circuit using a robust connection method such as...

- Crimp connectors
- Screw terminal connector block
- Snap fit automotive tap connectors

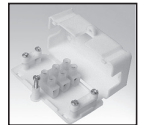
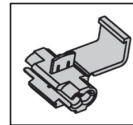

Caravans

Power can be taken directly from the leisure battery on the caravan. The ignition cable should be connected to the ignition key circuit which can be traced using the charts below. The caravan will either be fitted with the 13 Pin Euro Connector or have two 7/8 Pin connectors.

Terminal No.	Function	13 core wire colour
13 Pin Euro Connector		
1	Left Hand Indicator	Yellow
2	Rear fog light(s)	Blue
3	Earth for contacts 1 to 8	White
4	Right Hand Indicator	Green
5	Right Hand Side lights, marker lights & number plate light.	Brown
6	Brake lights	Red
7	Left Hand Side lights, marker lights & number plate light.	Black
8	Reversing light(s)	Pink
9	Positive direct from battery (Power)	Orange
10	Positive ignition key on (Fridge)	Grey
11	Earth return for contact 10	White/Black
12	Signalling connection to trailer	White/Blue
13	Earth return for contact 9	White/Red
12S 7 Pin Connector		
1	Reversing light(s)	Yellow
2	Positive ignition key on (Battery Charging)	Blue
3	Earth	White
4	Positive direct from battery (Power)	Green
5	Reverse Sensor (Optional)	Brown
6	Positive ignition key on (Fridge)	Red
7	Earth return for contact 6	Black

Caution: All electrical work should be carried out by a competent person. If in doubt seek advice from a qualified electrician.

Attach antenna unit to mounting plate:

Carefully lower the Antenna Unit onto the Mounting Plate and re-attach the M6 Nuts and Washers that were previously removed.

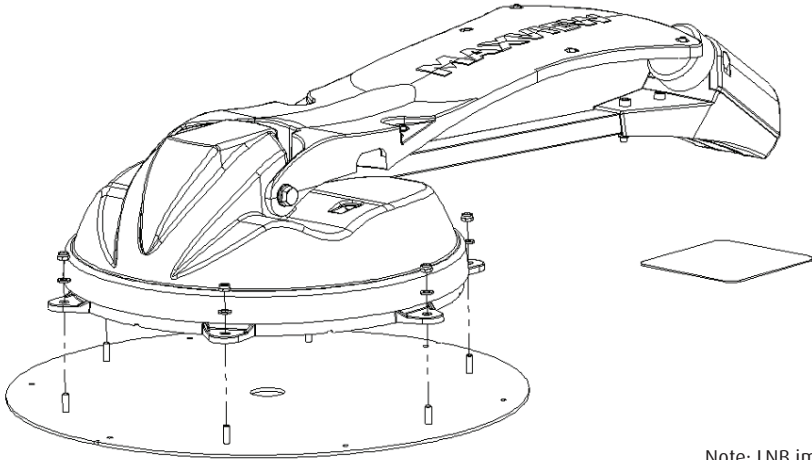

Caution:

Note: LNB image shows different model.

Replace Nylon locking nuts if they have been removed more than twice. The locking action of the Nylon becomes less effective if repeatedly assembled and disassembled.

Installing cables:

1. Check there are no hidden cables in the roof structure and that the hole location is clear of obstructions both internally and externally.
2. Turn over for Cable Entry Cover installation instructions

Application example:

Note: LNB image shows different model.

For quad variants you may need a 2nd cable entry plate.

Use extra Cable Entry Plate to route 2nd Sat feed to a different location.
Available to order from Maxview MXL018

Direction of travel
(front of vehicle)

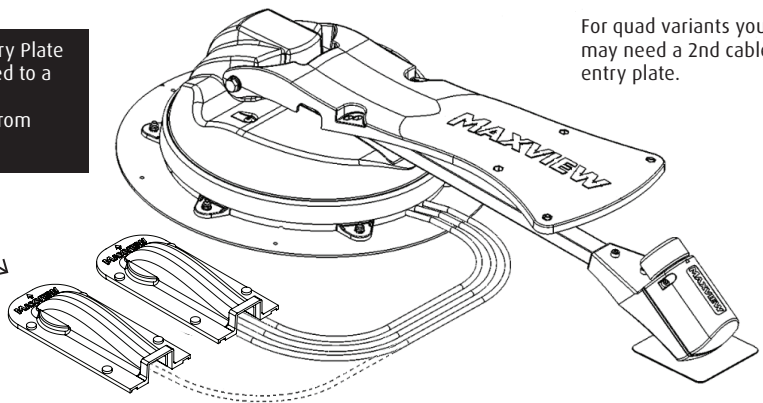



Note: To prevent trip hazards it is recommended that cables are concealed in PVCu conduit (not supplied) where access is required to the roof of the vehicle.

Installing Cable Entry Cover

1. Plan your installation carefully
2. Drill a 32mm hole in roof
3. Prepare surface for adhesion
4. Apply sealant as shown in A,B,C (we recommend Sikaflex-512 Caravan)*
5. Position top hat
6. Position cable entry cover
7. Wipe excess sealant with a dry cloth

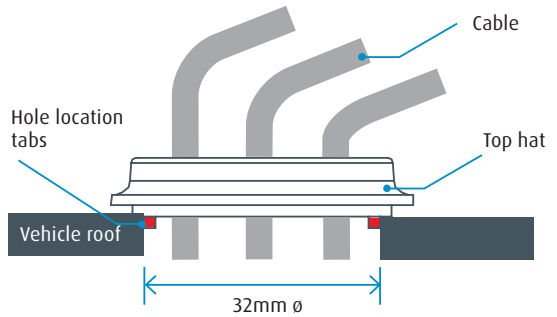
Applying sealant example:



 = Generously apply wet seal adhesive

Installing Control Box

Having previously chosen a suitable location

1. Clip the mounting brackets onto the Control Box.
2. Place Control Box on the horizontal or vertical surface and mark the 4 holes.
3. Depending on material drill a pilot hole or use a bradawl.
4. Attach cables to Control Box refer to page 11 for details.
5. Screw Control Box into position using 4 x No. 6 Screws.

Mounting positions:

Position the Control Box in one of the 4 ways shown left. Make sure that the front is easily accessible.

Fitting the Control Box Brackets:

The brackets snap fit to the Control Box casing

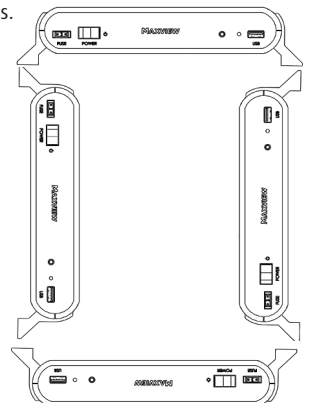
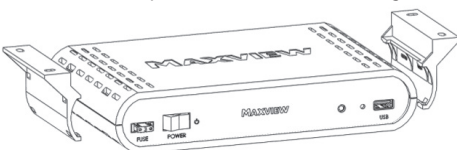

Connection diagram:

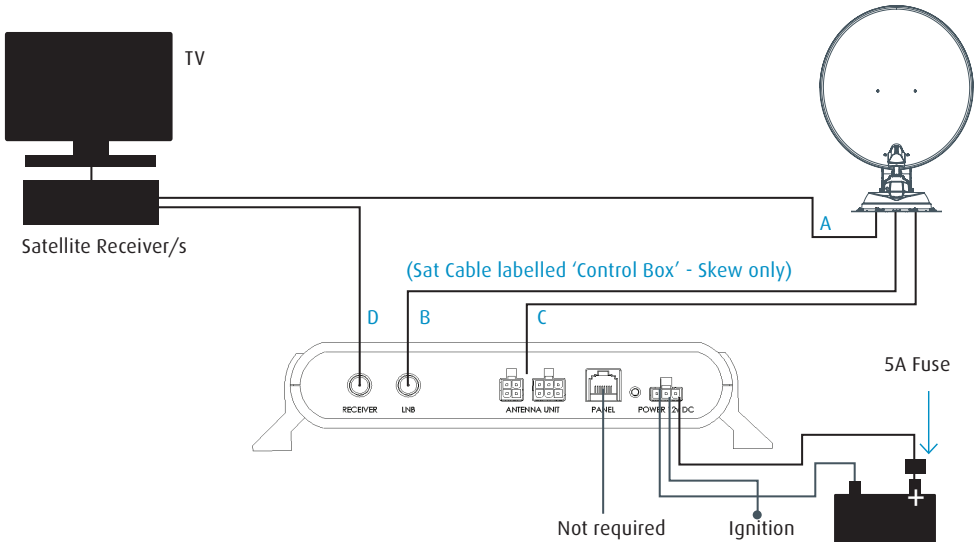

Key:

A: Satellite Cable B: Satellite Cable. **Note:** For Skew variants, satellite cable labelled 'Control Box' must be routed to 'B' C: Antenna Cable D: Cable for PVR or additional Satellite Receiver

Attach Satellite Dish to Antenna Unit - For 65cm & 85cm only 50cm is already attached.

1. Ensure Antenna Unit is free from obstacles.
2. Press installation button on reverse of Control Box to elevate antenna. Once elevated turn off power to Control Box and remove fuse.
3. Fix Satellite Dish to Antenna Arm using M6 Button Head Screws, M6 Nuts and 6mm Plastic Washers. The 65cm and 85cm satellite dishes have different fixing hole positions. Therefore 4 of the holes will be unused.
4. Remove all tools, packaging and obstructions from roof.
5. Replace fuse and turn power switch on. Antenna will automatically retract into the park position.

Caution:

Replace Nylon locking nuts if they have been removed more than twice. The locking action of the Nylon becomes less effective if repeatedly assembled and disassembled.

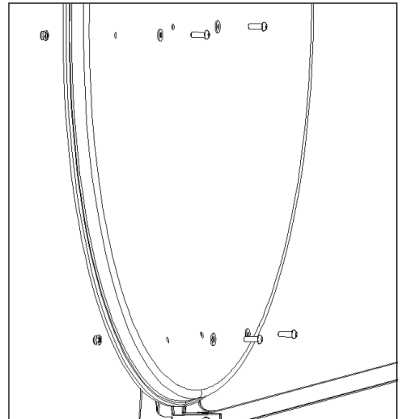

Testing Antenna Unit:

Position the vehicle so that there is an unobstructed view of the southern sky. Connect a TV and Satellite Receiver and follow instructions on page 12 to search for a satellite.

Caution:

Before driving vehicle on a highway ensure adhesive has cured. Check all fasteners are secure.

Finding a satellite:

Before starting check there is a clear line of sight to the southern sky. All television broadcasting satellites have a geostationary orbit which means their location is fixed above the earth's equator. Satellites also have a limited range of transmission so use the Zone maps included in the appendix to check your location is suitable for reception. If your location is near the limit of reception it is recommended to adjust the skew angle of the LNB to maximise signal quality and strength (see page 18 for details)

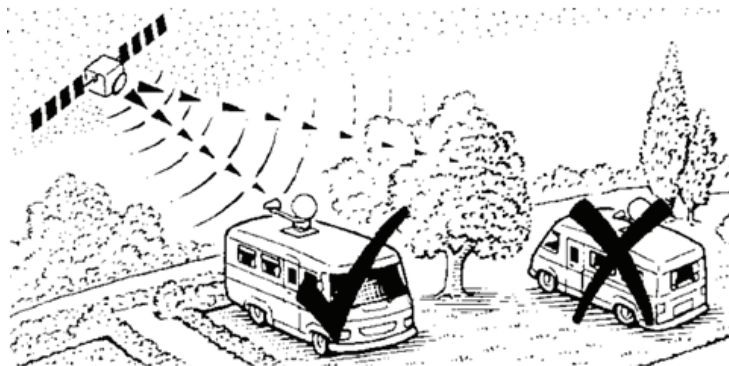

Note: The Target works independently from a Satellite Receiver. Therefore, any satellite receiver can be used. Ensure the TV and Satellite Receiver are connected in accordance to the manufacturer's instructions.

Reference

5 pre-programmed satellites as standard* (Astra 1 19.2°, Astra 2 28.2°, Astra 3 23.5°, Hotbird 13° & Thor 0.8°)

Ref	Satellite	Notes
1.	ASTRA 1	
2.	ASTRA 2	For UK English channels. Eg. BBC, ITV, Channel 4 etc
3.	ASTRA 3	
4.	HOTBIRD	
5.	THOR	

*Satellite downloads (other satellite packages available as USB update)

Interface details

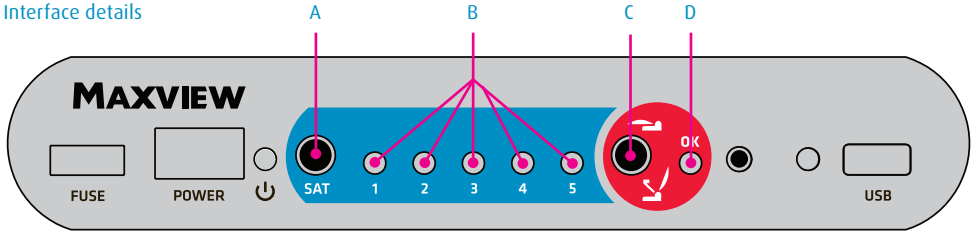

- A. Select satellite
- B. LED shows you which satellite is selected
- C. SEARCH - Press and release
PARK - Press and hold for 3 seconds
- D. Satellite found LED (green FOUND)

How to operate your system

1. Turn on Power on Flashes green

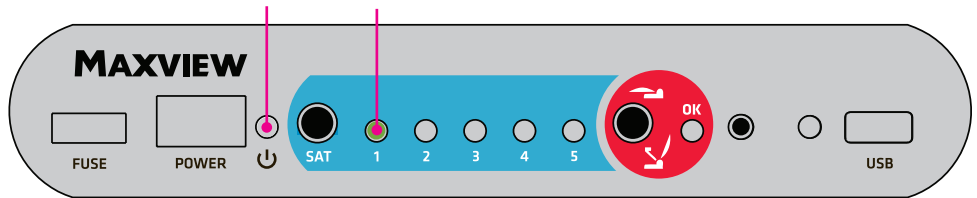

Switch the power on. The LED flashes green on the last satellite you selected.

2. To change satellite* Press Flashes green

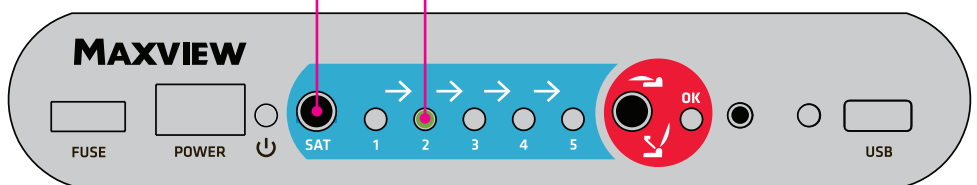

*If required. Press SAT to scroll through satellite selection. Eg. New selected SAT LED will flash green.

3. Search Flashes green Search Flashes green

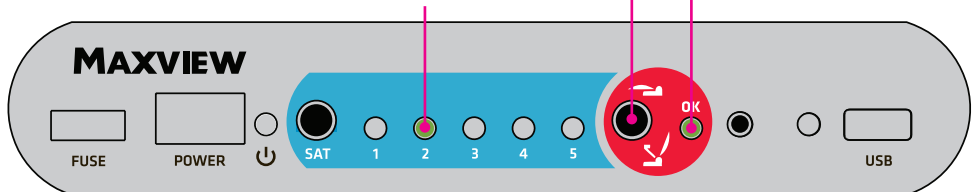

SEARCH - Press and release to begin. Both the OK LED and LED selected will flash during search.

4. Satellite Found

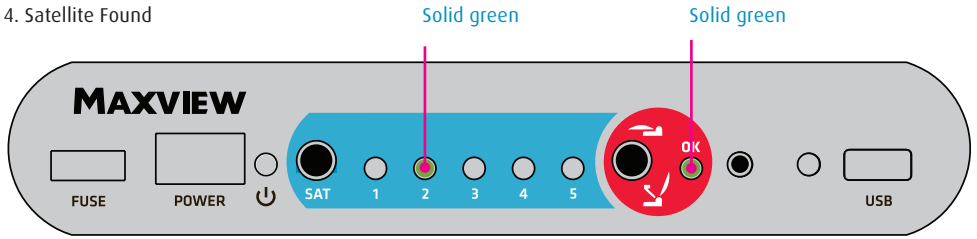

Once the satellite has been found the OK LED and the satellite selected will show solid green.

5. Park System

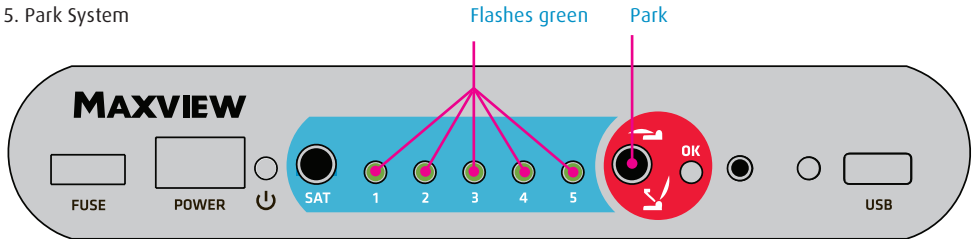

PARK - Press and hold for 3 seconds. LED's 1 to 5 flash green to indicate system is collapsing. Once fully collapsed, control panel can be powered off.

Ignition mode:

The ignition mode is a safety feature that automatically lowers the antenna and prevents accidental operation whilst travelling. When the Target has detected an active ignition circuit in the vehicle the antenna is automatically lowered.

Note: The Control Box must be wired to a 12v DC electrical circuit that is live when the vehicle's ignition is on. This not only provides a safety benefit but also refreshes the Control Box memory which allows the Target to perform correctly.

Connecting to a Satellite Receiver:

The satellite cables must connect to the Control Box. The Control Box will then output this signal through the F connector marked 'RECEIVER'. In order for the satellite signal to pass through the Control Box the power must be on.

Power consumption:

The Target has been designed to minimise power consumption. When the Target is not used for long periods of time it is recommended to switch off the Control Box. The Ignition Mode will still activate even with the Control Box power switch in the off position. When power is restored to the system the antenna will automatically lower into the park position.

Software update:

To keep your Target up to date with the latest satellites Maxview has incorporated a USB port on the front of the Control Box. The Target has the ability to update its satellite data and its operational software from a simple USB flash memory stick.

Please visit www.maxview.co.uk - search: Target - Downloads for latest software and a guide to installation.

Preparing a USB Flash Memory Stick:

1. Use a blank USB flash memory stick formatted to FAT or FAT32
2. Format USB stick:
3. In Windows XP, Vista or Windows 7
4. Insert USB key in PC, find device in 'My Computer', right click and
5. Select 'Format...'
6. Select options as shown below press start.

Update Control Box software:

1. Obtain a update-xxxx.hex file from Maxview and copy onto a formatted USB flash memory stick.
2. Turn on Control Box.
3. Press and hold the SYNC button on the front of the Control Box for 7 seconds until SYNC LED illuminates RED.
4. Insert the USB flash memory stick. The SYNC LED will flash GREEN whilst data is being transferred.
5. When the SYNC LED goes out turn off the Control Box power and remove the USB flash memory stick.
6. Turn power on, SYNC LED will flash RED and GREEN whilst data is written to Control Box memory.
7. When SYNC LED goes out update is complete.

Note: If status LED does not flash RED and GREEN when power is restored after update then the software has not been loaded successfully. Check the read me file created by the Control Box on the USB flash memory stick for details. An update will not be successful if the file to be loaded is the same as the one already stored in the Control Box. If you experience difficulties please contact Maxview Customer Service.

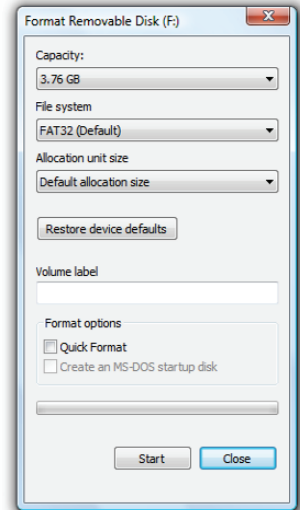

Fault finding:

	Problem	Actions
Control Box	No power	Check Fuse Check Power cable connection Leisure battery voltage is low
	Fuse blows repeatedly	Check Fuse rating is 4A Check antenna unit is not obstructed Contact Maxview Customer Service
	USB update failed	Check file was added to a blank FAT formatted USB memory stick After update check text file added to USB memory stick Contact Maxview Customer Service
Antenna	Antenna stuck in elevated position	DO NOT TRAVEL UNTIL ANTENNA UNIT IS REMOVED Contact Maxview Customer Service

Error modes:

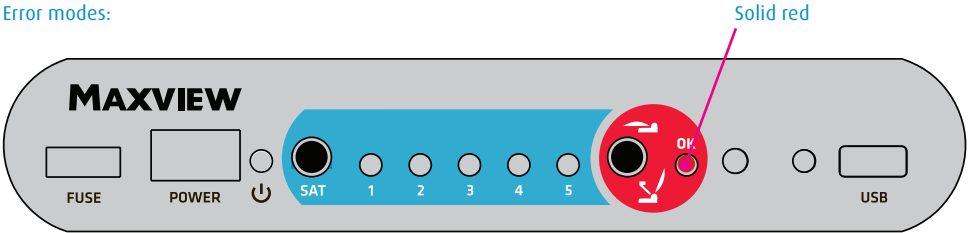

A. No SAT found. If searching and no satellite found the 'flashing green' LED will go solid RED
After 5 seconds the dish will then move to park position

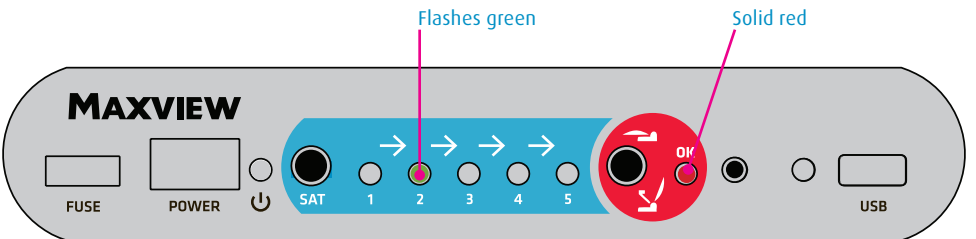

B. No SAT found - system parked. Once parked the Search LED stays solid RED and SAT LED searched continues to flash green

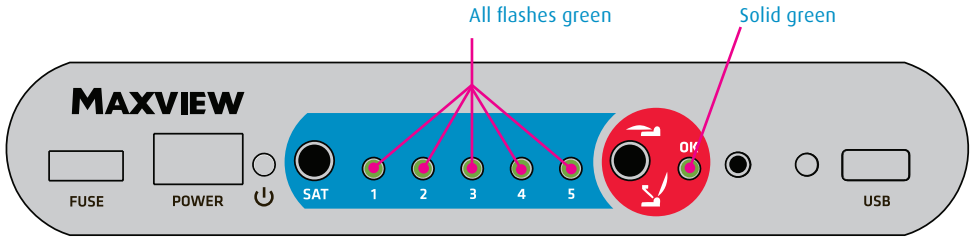

C. **Ignition mode parking.** When the antenna is parking using the Ignition (green wire) all sat LEDs flash green

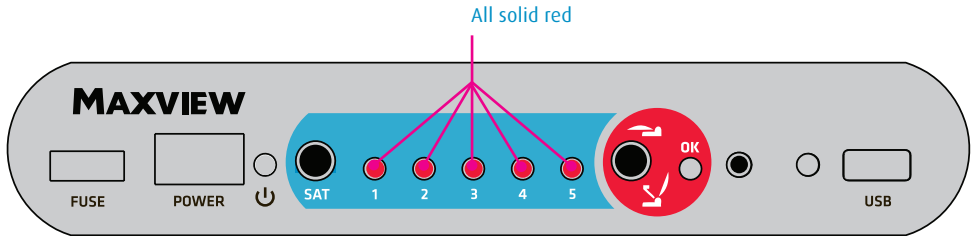

D. **Ignition mode parked.** When system parked during ignition mode all the SAT LED's stop flashing green and ALL 5 LED's go solid RED.

During Ignition mode ALL control buttons have no function (locked).

Once 'Ignition off' last satellite found LED start to flash and ready to search (keys active again).

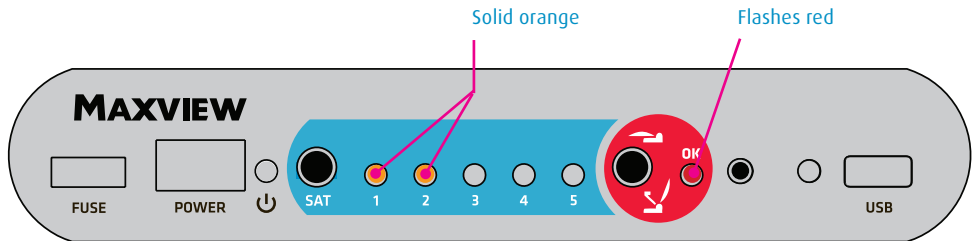

E. **Azimuth Error.** If rotation motor stops the above LED sequence will occur, please contact Customer Services.

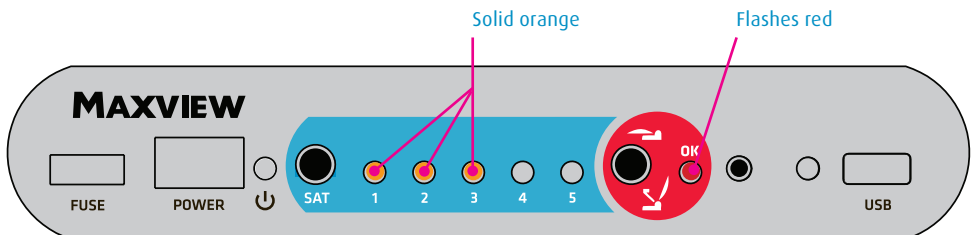

F. **Elevation Error.** If elevation motor stops the above LED sequence will occur, please contact Customer Services.

Skew Adjustment:

Skew adjustment requires rotation of the LNB in order to improve signal quality at the edge of a satellite footprint. If you have purchased a manual skew product variant, this LNB rotation adjustment must be completed by hand* using the appropriate skew angle map.

*Caution: Follow general safety advice on page 3 when carrying out manual skew adjustment.

If you have purchased an automatic skew variant the above is not applicable. Your system will use GPS to automatically rotate the LNB to the correct skew for your given location, therefore maximising satellite reception. This process is completely automatic when the search command is started. It requires no further input from the customer.

With Automatic Skew, you can rest assured that your system has maximised the signal quality for your location.

If you have any further questions regarding manual or automatic skew adjustment, please contact Maxview Customer Services on +44 (0)1553 811000 or visit www.maxview.co.uk.



Astra 2 - 28.2°

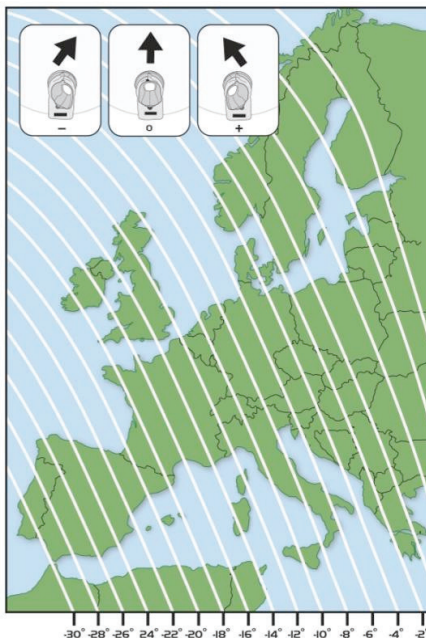

Astra 1 - 19.2°



3 year guarantee:

Every new Target System is thoroughly inspected and tested before leaving the factory and is covered by our three years guarantee from the date of original purchase.

Maxview is responsible for the cost of a replacement part if the original part is determined to be defective under the terms of guarantee. The customer is responsible for the cost of replacement parts after three years. This guarantee does not cover installation or external wiring.

Should any trouble develop during the guarantee period please contact Maxview before the expiry date .If you do experience a problem with the product contact Maxview Customer Services on +44 (0)1553 811000 or email support@maxview.co.uk

Please make sure you have the following ready when you call:

- **Model number** • **Serial number** • **Date of purchase** • **Clear and concise details of the fault**
- **Details of who installed the product**

The guarantee does not apply where:

- If the ignition cable is not installed
- The product has been abused, misused, improperly installed or improperly maintained.
- The product has been installed without the use of Maxview mounting brackets
- Repairs have been made or attempted by a third party other than Maxview
- Repairs are required due to normal wear and tear
- Modifications have been made to the product
- The antenna unit or control box has been opened
- Damaged caused by abrasive cleaning or power washing
- Circumstances beyond the control of Maxview that have caused the product to no longer operate correctly
- Customer cannot provide proof of purchase

In no event shall Maxview be liable for any indirect, incidental, or consequential damages from the sale or use of the product. This disclaimer applies both during and after the term of the guarantee. This does not affect your statutory rights

Environment:

Information for users on collection and disposal of old equipment and used batteries



These symbols on the products, packaging, and/or accompanying documents mean that used electrical and electronic products and batteries should not be mixed with general household waste. For proper treatment, recovery and recycling of old products and used batteries, please take them to applicable collection points, in accordance with your national legislation and the Directives 2002/96/EC and 2006/66/EC.



By disposing of these products and batteries correctly, you will help to save valuable resources and prevent any potential negative effects on human health and the environment which could otherwise arise from inappropriate waste handling.



For more information about collection and recycling of old products and batteries, please contact your local authority, your waste disposal service or the point of sale where you purchased the items. Penalties may be applicable for incorrect disposal of this waste, in accordance with national legislation.

For business users in the European Union

If you wish to discard electrical and electronic equipment, please contact your dealer or supplier for further information. [Information on Disposal in other Countries outside the European Union]

These symbols are only valid in the European Union. If you wish to discard these items, please contact your local authority or dealer and ask for the correct method of disposal.

Note: for the battery symbol (bottom two symbol examples): This symbol might be used in combination with a chemical symbol. In this case it complies with the requirement set by the Directive for the chemical involved.

Specifications:

Operating: Average search time 30-60 seconds typical Future proof with free software updates via a USB stick - see page 15 Low stream line profile, only 17cm in park position 5 Pre-programmed including: Astra 1 19.2°, Astra 2 28.2°, Astra 3 23.5°, Hotbird 13° & Thor 0.8°	
Power: Powering: 12V operation Power Consumption: Maximum 2A consumption during search Standby Current: 0.2A Fuse Type: 4A Mini Blade Automotive (In Control Box)	
System: Elevation Range: 10° to 70° Azimuth Range: 380° Skew Angle: ±45° (Manual or Automatic, dependant on variant) Operating Temp: -15° to 40° C Safety System: Automatic lowering ignition Cable Type: CAI approved 100 coaxial cable UV Protection: All external plastic parts are UV stabilised Testing: Fully weatherproof and watertight construction System has passed extensive water ingress test	
LNB: Type: High Quality low noise Universal Single, Twin or Quad LNB Output: Single, Twin or Quad Typical Gain: 50cm - 34.8dB 65cm - 36dB 85cm - 38.1dB Frequency Range: 10.7-12.75GHz Arm Cable: RG179	
Antenna: Material: Aluminium Reflector Thickness: 1mm Finish: Powder coated with U.V. inhibited polyester-based Outside Dims: 50cm dish: 50 x 53cm 65cm dish: 67.0 x 71.5 cm 85cm dish: 85.0 x 90.5 cm Reflecting Dims: 50cm dish: 50 x 53cm 65cm dish: 63.0 x 67.5 cm 85cm dish: 81.5 x 87 cm	
Mounting: Plate Material: Aluminium Fixing Method: Recommended adhesive (Sikaflex, Geocel or equivalent) Fixing Studs: 6 x M5 studs for system removal Cable Entry: Coaxial cable joining cover under antenna system	



CE Declaration of Conformity

The Target Satellite Antenna has been designed, constructed and marketed in compliance with safety requirements of EEC Directive 2006/95/EEC (Low voltage) and requirements of EMC Directive 2004/108/EEC.