

Initial retailer information

The new Truma iNet X System

July 2021



heating | cooling | controlling



More comfort on the move

The new Truma iNet X System

start smart. **be smart.** stay smart.

With the new Truma iNet X System and the intuitive iNet X Panels, we are laying the foundations for networked and smart vehicles which are fit for the future.

The fact that the system is updatable also ensures continuous further development to include new

applications, features and products - so you are always one step ahead! Smart solutions for more comfort, safety and sustainability result in added value for your customers and your business.

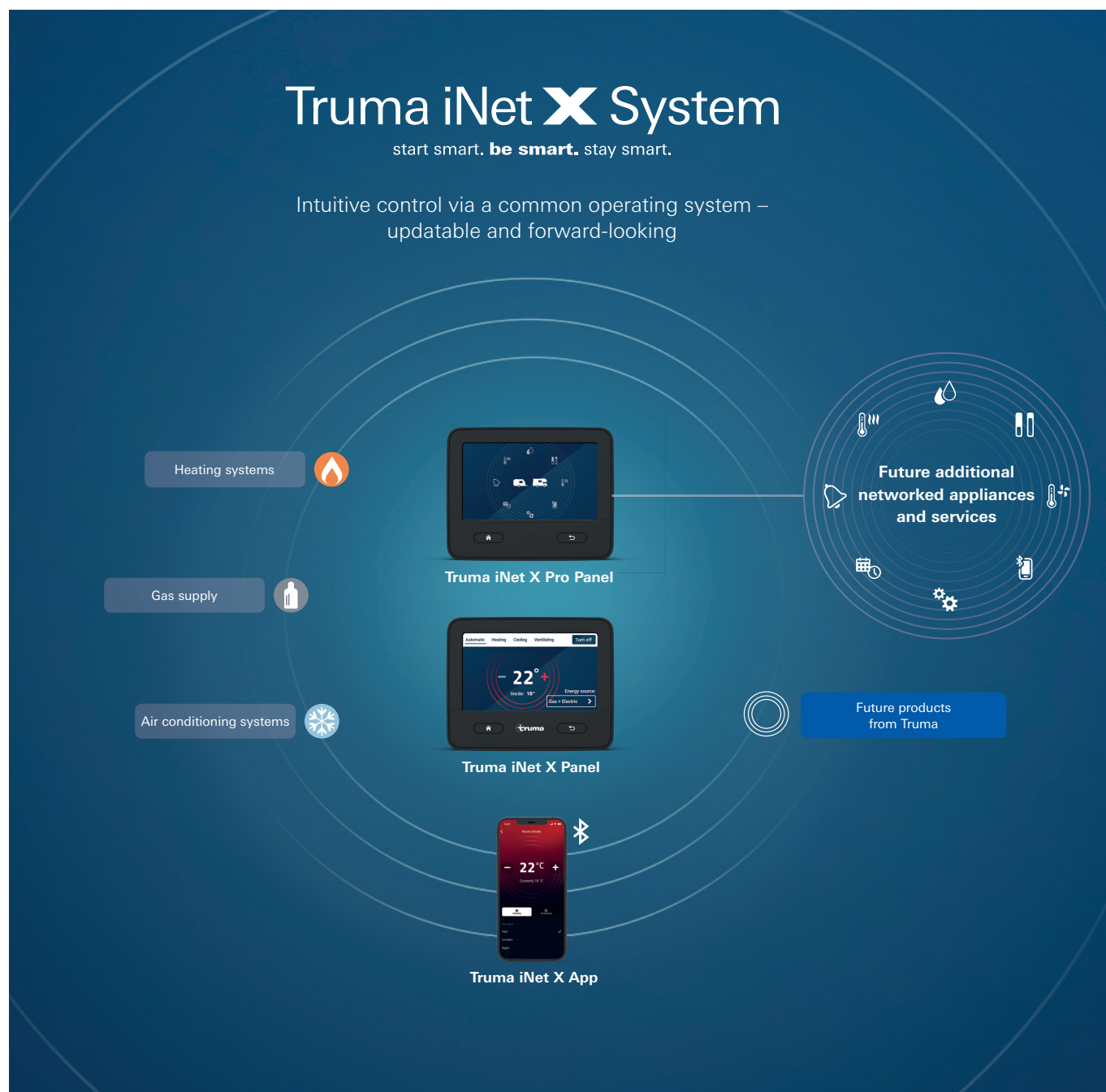

The new Truma iNet X Panels

Truma iNet X Panel



The new Truma iNet X Panel enables connection and control of Truma products as well as Freshjet air conditioners from Dometic.

The new Truma iNet X Panel is available from early 2022 for retrofitting. In this way, for example, CP classic and CP plus can be replaced by this central control panel.

Since control is much simpler and more convenient for the user – and you have the opportunity as a specialist dealer to position yourself as an innovative partner for RV owners, there are particularly impressive arguments for retrofitting, such as the touch display and intuitive operation and app control via Bluetooth.

Technical highlights

- 4.3" colour display
- Touchscreen operation
- Battery for memory
- App control via Bluetooth
- Updatable
- Intuitive and multilingual menu navigation
- Indoor and outdoor temperature display
- iNet X Connect can be retrofitted for remote operation
- Intelligent fan control
- Intelligent heater and hot water boost

The new Truma iNet X Panels

Truma iNet X Pro Panel



The new Truma iNet X Pro Panel enables connection and control of various appliances, services and applications via one central control panel.

It is not restricted to Truma products.

The most noticeable change to the new Truma iNet X Panel is in the open system architecture with various interfaces.

The new Truma iNet X Pro Panel will be on board with various vehicle manufacturers for the new 2022 season.

Technical highlights

- 4.3" colour display
- Touchscreen operation
- Battery for memory
- App control via Bluetooth
- Updatable
- Intuitive and multilingual menu navigation
- Indoor and outdoor temperature display
- iNet X Connect can be retrofitted for remote operation
- Intelligent fan control
- Intelligent heater and hot water boost
- Resource request possible
- Individual switching scenarios

A comparison of both control panels

		Truma iNet X Panel	Truma iNet X Pro Panel
Intuitive app control via Bluetooth		Yes	Yes
Operation of Truma appliances (Heating / water, air conditioning, LevelControl)	Combi (D) (E) Saphir, Aventa	Yes	Yes
LevelControl		Yes	Yes
Operation of Alde appliances	Alde 3020 HE	No	Yes
Third-party air conditioners	Dometic Freshjet	Yes	Yes
Integration of filling level sensors (battery, water) for switches (Main-, pump switch, multimedia, light)	EBL adapter, IBS	No	Yes
Indoor & outdoor temperature sensors on the panel		Yes	Yes
Future enhancements with new products and services		Yes	Yes

The new Truma iNet X App

for even more convenience



Our new Truma iNet X App offers the same well designed menu navigation and the same look as our panels and is therefore rather easy to operate.



Further details on the new Truma iNet X System will be with you shortly, just hold on

All information is of course also available online at:
<https://www.truma.com>
simply scan the QR code.

Have we caught your attention?

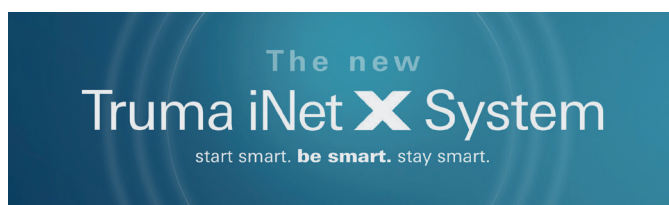

Visit us at
Caravan Salon in Düsseldorf
Hall 14 Booth B07

The advantages of the new Truma iNet X System

For you as a specialist dealer:

- **Put simply:** Using the panel solution and the app is intuitive. Truma also creates how-to videos and FAQs for end customers.
- **Constantly evolving:** The solutions are continually optimised. If a customer is experiencing individual problems, Truma Service offers support with a personal touch.
- **Fully supported:** Truma supports your sales through its own marketing initiatives and promotes appliances that can be connected to the Truma iNet X System.
- **Directly with the final user:** The basis of future development is regularly exchanging ideas with our customers, dealers and manufacturers. Users are at the heart of our developments and steer us in the right direction. In future, we therefore want to be more heavily involved in Truma community thoughts and ideas.

For your customers:

- **Smart networking:** Easy to control appliances from various manufacturers via a central operating system. New services thanks to intelligent devices.
- **Forward-looking:** Updates allow us to integrate future products and functions - always keeping you up-to-date.
- **Reliable:** Regular further developments ensure a continuously high level of quality – fast help thanks to detailed error display and customer service with a personal touch.
- **Easy operation:** Intuitive touchscreen panel and free App – from mid 2022 it can also be controlled when you're out and about.
- **Customer focus:** Regular customer surveys and interviews form the basis of our further development. The needs and issues faced by campers are paramount here and steer us in the right direction for future developments.

Technical specifications

Truma iNet X Panel

Control panel dimensions

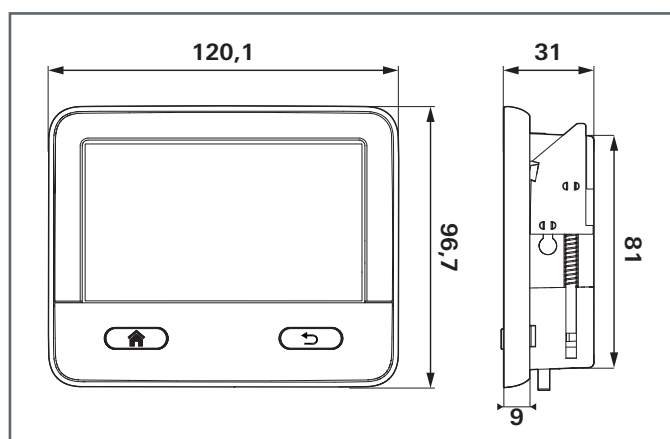

all dimensions in mm

Languages

DE / EN / FR / IT / ES / SE

Connections

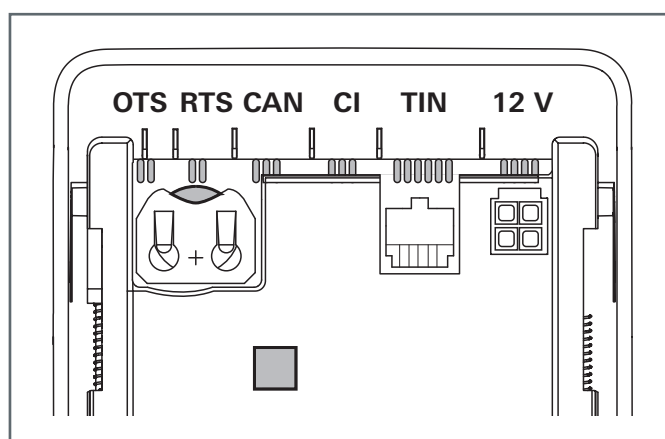

Technical specifications

Size	Value
Touchscreen display	TFT-LCD 4.3" (resistive)
Operating temperature range	-30°C to +60°C
Storage temperature range	-30°C to +60°C
Interfaces	TIN bus, CI-Bus, CAN-Bus, Bluetooth Low Energy (BLE)
Bluetooth	Output power: 5 dBm Tune-up tolerance: +/- 3 dB
Power supply	Typ. 12 V (8 V - 16 V)
Power consumption	Typ. 1.5 W
Battery	Lithium round cell battery 3 V CR 2032
Weight	Approx. 150 kg
Protection class	Class III
Protection type	Front: IP20 Rear: IP00



Truma Gerätetechnik GmbH & Co. KG
Wernher-von-Braun-Straße 12
85640 Putzbrunn
Germany
Telefon +49 (0)89 4617-2020
customer care@truma.com

Subject to technical changes.

www.truma.com

 **truma**
More comfort on the move